

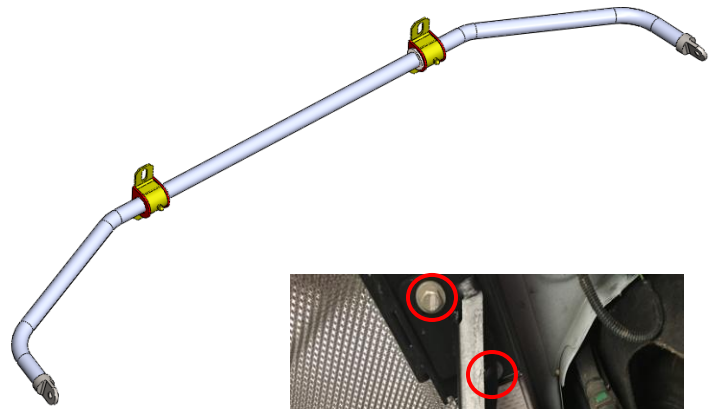

## Rear Swaybar

### 2016+ Ford Focus RS

Installation Instructions For Kit #555-1019



- A qualified technician should be used if you are not confident with replacing the rear swaybar assembly.

#### Removal of the factory rear swaybar

1. Lift the rear of the car so that the rear wheels are off the ground. Use caution operating a lift or jack stands to ensure the car is stable and safe to work around and underneath.
2. Remove the two flange head bolts and the TORX button head bolt from the support braces. See figure 1. Repeat for the opposite side.
3. Remove the 18mm flange nut from the swaybar end link by using an 18mm box end wrench and a 6mm hex key. See figure 2. Repeat for the opposite side. NOTE: Do NOT allow the ball joint stud to spin as this may cause damage to the joint.
4. Remove the two 13mm head flange bolts from the swaybar subframe mounts. See figure 2. Repeat for the opposite side.
5. Remove the swaybar assembly from the car.

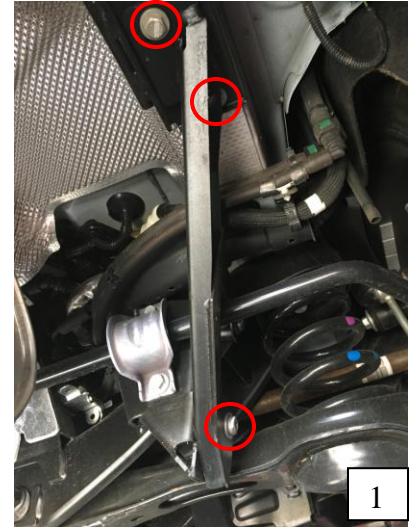

#### Installation of the Steeda rear swaybar

6. Generously grease the inside of the polyurethane swaybar bushings and the outside of the centering washers with the supplied grease packet.
7. Slip the bushings and brackets over the swaybar to the outside of the centering washers. See figure 3.
8. Install the swaybar in the same location and orientation as the factory swaybar. Use the provided spacer in between the subframe and the swaybar bracket.
9. Torque the swaybar bolts to 42 ft-lbs.
10. Reinstall all factory components that were removed.

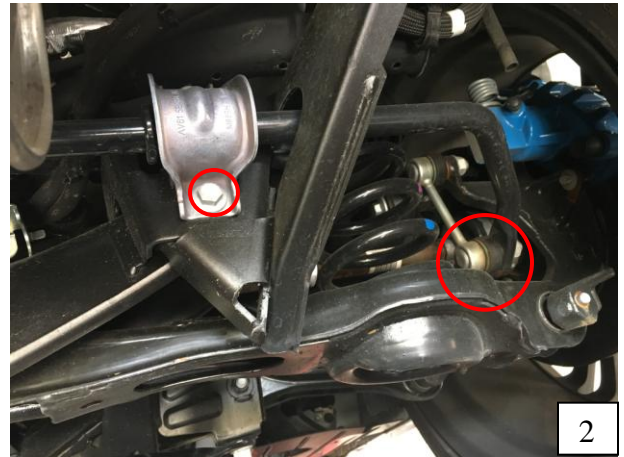

Thank you for choosing Steeda Autosports! If you have any questions or comments please call us at 954-960-0774 or email [GoFast@Steeda.com](mailto:GoFast@Steeda.com)